

User Guide

# TurboHarp®

[www.turboharp.com](http://www.turboharp.com)

HARMONICAS OF THE FUTURE

## TurboSlide



30 day  
satisfaction  
Guarantee

Bend notes like you've never bent before!

[www.turboharp.com](http://www.turboharp.com)



ANTAKAMATICS, INC.  
3500 Fifth Avenue, #602  
Pittsburgh, PA 15213  
[www.turboharp.com](http://www.turboharp.com)  
[www.antakamatics.com](http://www.antakamatics.com)

Model TS-003

rev: 10.20.2010

PATENT PENDING

*Congratulations on being one of the first kids on your block to own a **TurboSlide™** harp – the latest innovation from our development bench. We hope you have fun with it, and greatly appreciate your support... and constructive criticism.*



## BACKGROUND

Since the very origins of the harmonica, dating back to the early Chinese Sheng 3000 years ago, its physical principles of operation have remained basically unchanged. The sound generator, the free reed, produces a note by periodically interrupting the flow of air through the instrument. The pitch of the note produced by reed is determined by three factors: its mass, its stiffness, and the resonance of the air path (which includes the player's oral cavity.)

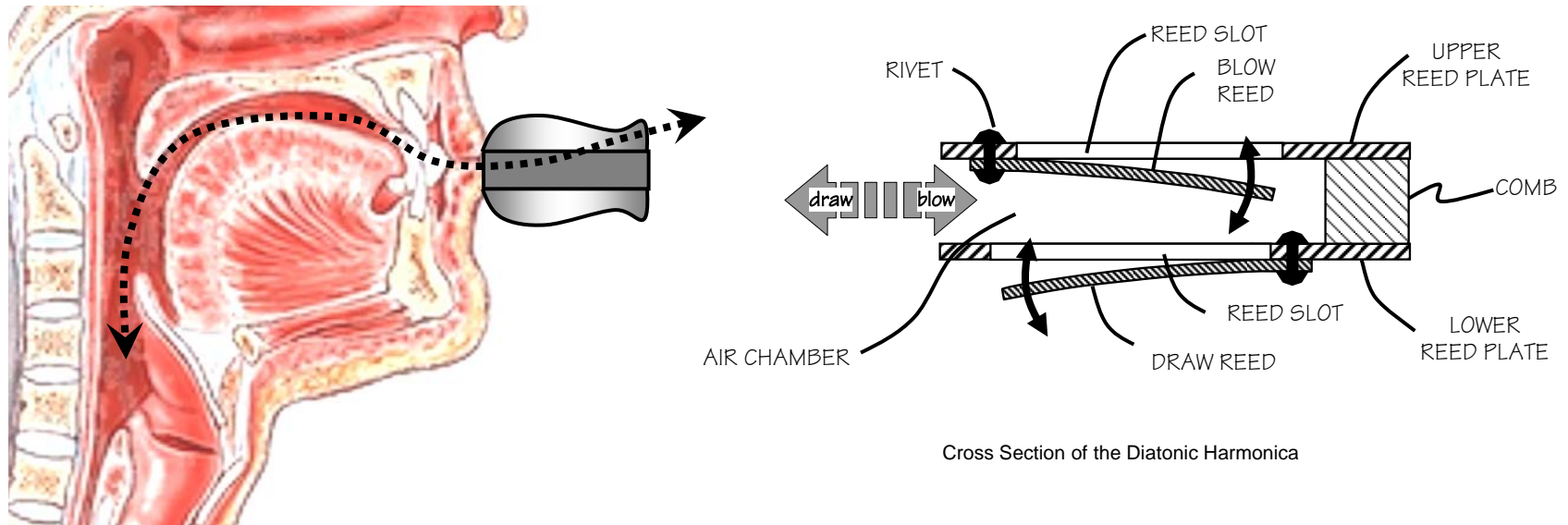

Cross Section of the Diatonic Harmonica

As you are probably aware, the player may alter the mass and stiffness the reeds by sanding, scraping or filing material from either the tip or the root, respectively. He/she may also modulate the resonance of the air path through *bending* or *overbending*.

By appropriately altering his/her embouchure, a player can achieve several of the “missing” notes not normally provided by the diatonic scale. Some notes may be “bent” lower, others “overblown” or “overblown” higher. These are summarized in the diagram below:

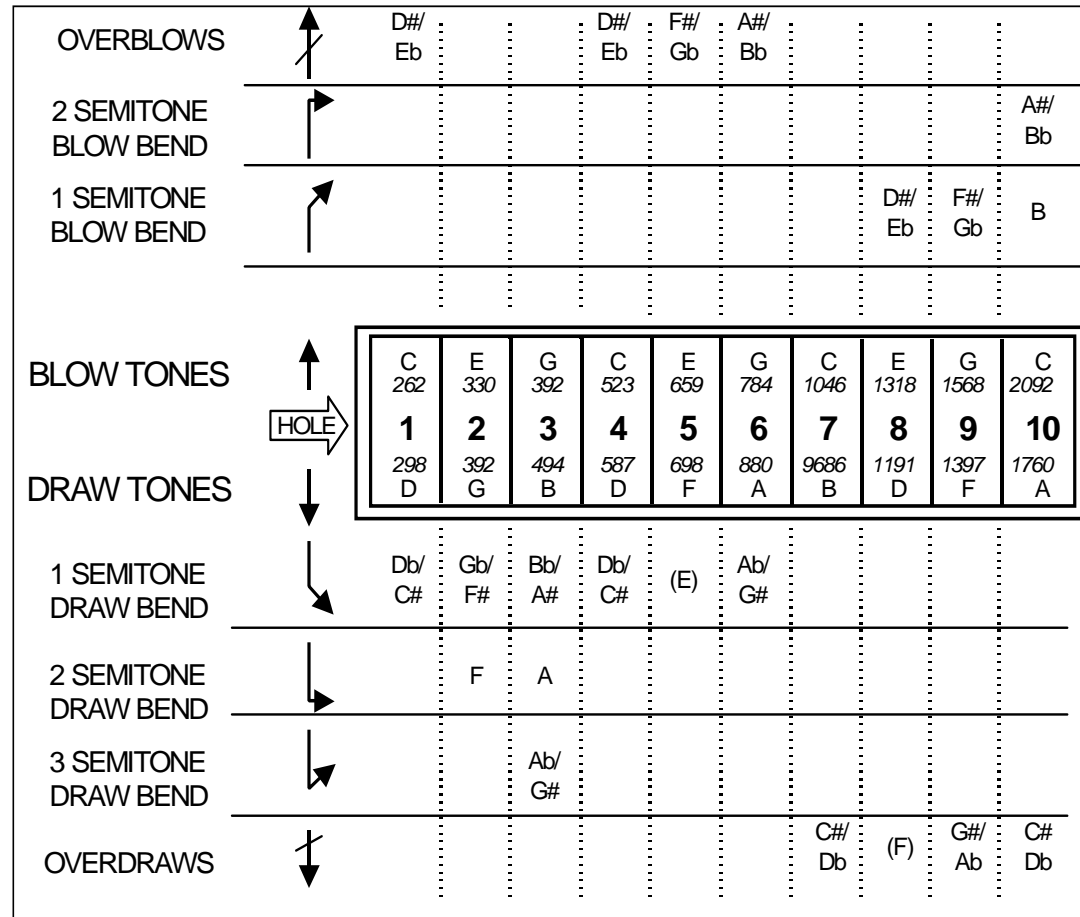

The lower “bendable” notes typically provide a smooth transition between the natural pitch of the draw reed and approximately a semitone below the pitch of the blow reed. The bends on the upper register, as well as the overblows and overdraws involve more sudden transition of pitch.

The Chromatic harmonica offers additional possibilities by providing additional reeds in each of the sound holes. A valved plate is typically needed to toggle between the natural note and a sharped note. Again, this provides a sudden transition of pitch, precluding a gradual transition and hence limiting the expression of the player.

## HOW IT WORKS

The *JurboSlide* represents a NEW generation of harmonica, somewhat adopting the characteristics of both the Diatonic and Chromatic harp. The physical principle of its operation is shown schematically below:

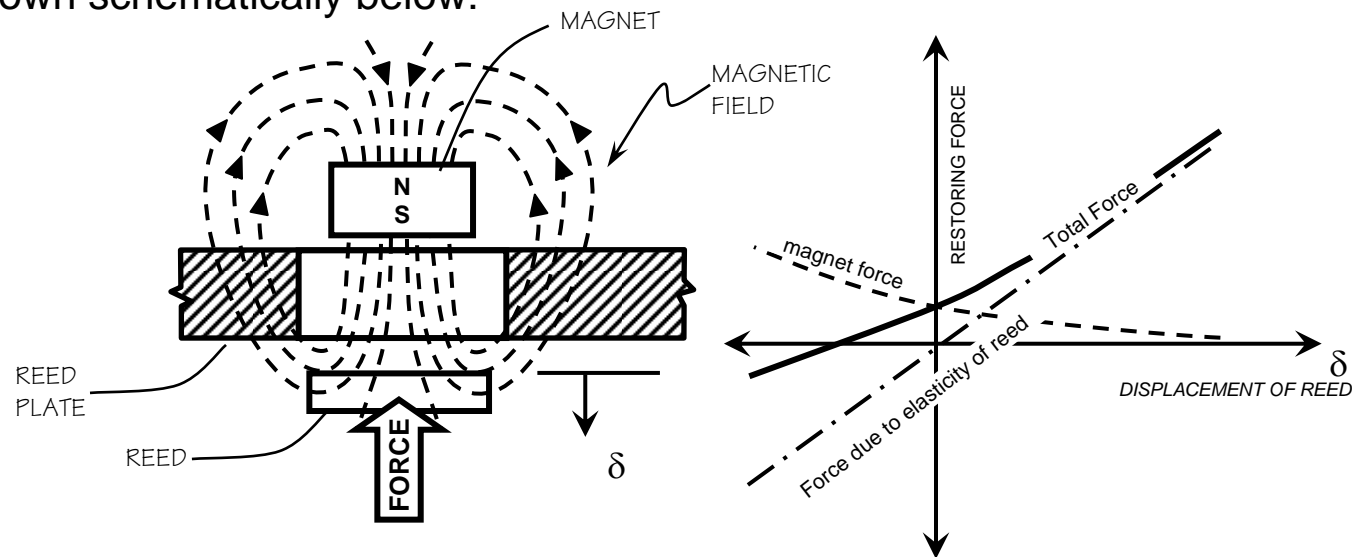

The *JurboSlide* employs a permanent magnet adjacent to the reed to alter its stiffness. From the diagram you can see that the relationship of force to displacement which is normally a straight line becomes more shallow when the magnetic force is added to it. Lower stiffness means lower pitch.

Then by sliding the magnet towards/away from the reed, the pitch can be adjusted manually. The current version *JurboSlide* is equipped with ten magnets attached to a common carriage. One magnet for each blow reed. (For reasons explained later, this model does not include magnets on the draw reeds.)

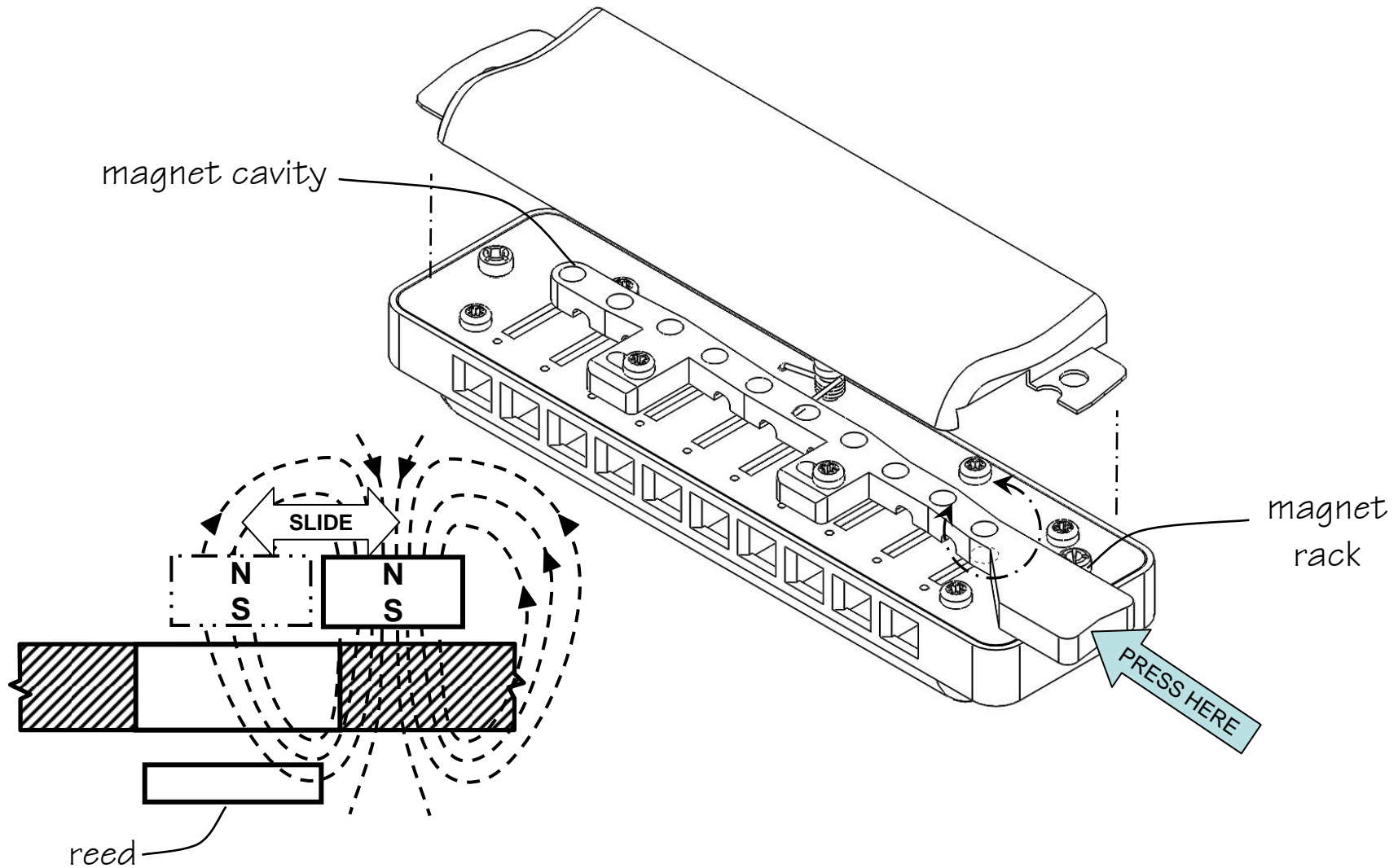

OK, you might be wondering why there are no magnets on the draw reeds. There are two reasons. One is that the draw reeds, at least on the lower register, are already easy to bend. Therefore there is not as big an advantage of a slide. On the other hand you might ask, “why not use the magnet in the opposite direction, to make the note sharper?” This is indeed technically possible, but more difficult. We therefore plan to add this feature in a later version of the *JurboSlide* harp.

Putting it all together, the TS-003 model *JurboSlide* provides the “missing” flatted semitones on the blow notes (green box below) and greater control over the bent notes of the top register (dotted box below.)

SHARPED SEMINTONE	D <sub>b</sub> C <sub>#</sub>	F	A <sub>b</sub> G <sub>#</sub>	D <sub>b</sub> C <sub>#</sub>	F	A <sub>b</sub> G <sub>#</sub>	D <sub>b</sub> C <sub>#</sub>	F	A <sub>b</sub> G <sub>#</sub>	D <sub>b</sub> C <sub>#</sub>
FLATTED SEMITONE	B	D <sub>#</sub> E <sub>b</sub>	F <sub>#</sub> G <sub>b</sub>	B	D <sub>#</sub> E <sub>b</sub>	F <sub>#</sub> G <sub>b</sub>	B	D <sub>#</sub> E <sub>b</sub>	F <sub>#</sub> G <sub>b</sub>	B
BLOW TONES	C 262	E 330	G 392	C 523	E 659	G 784	C 1046	E 1318	G 1568	C 2092
	1	2	3	4	5	6	7	8	9	10
DRAW TONES	298 D	392 G	494 B	587 D	698 F	880 A	9686 B	1191 D	1397 F	1760 A
FLATTED SEMITONE	D <sub>b</sub> C <sub>#</sub>	G <sub>b</sub> F <sub>#</sub>	B <sub>b</sub> / A <sub>#</sub>	D <sub>b</sub> C <sub>#</sub>	E	A <sub>b</sub> G <sub>#</sub>	B <sub>b</sub> A <sub>#</sub>	D <sub>b</sub> C <sub>#</sub>	E	A <sub>b</sub> G <sub>#</sub>
SHARPED SEMINTONE	D <sub>#</sub> E <sub>b</sub>	G <sub>#</sub> A <sub>b</sub>	C	D <sub>#</sub> E <sub>b</sub>	F <sub>#</sub> G <sub>b</sub>	A <sub>#</sub> B <sub>b</sub>	C	D <sub>#</sub> E <sub>b</sub>	F <sub>#</sub> G <sub>b</sub>	A <sub>#</sub> B <sub>b</sub>

Better yet, because the *TurboSlide* allows the altered notes to be phased in/out at will, the player is offered the ability to bend any of these notes smoothly.

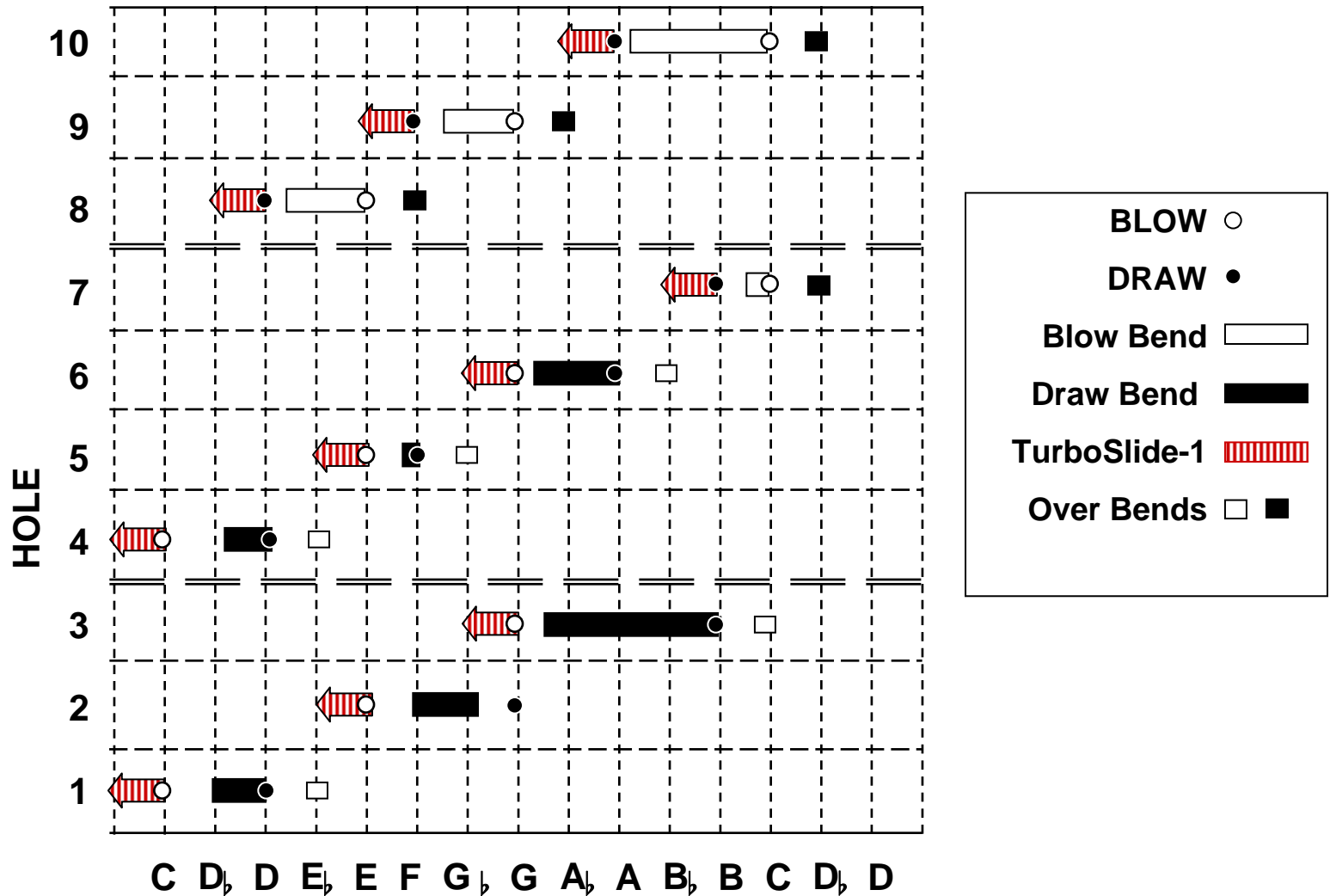

Slowly for soulful expression... or rapidly, to introduce tremolo.... One at a time; or all at once... By a half-step, or even whole step!

# *TurboSlide* of the Future

Here are some additional features from our development bench that we plan to add to future versions of the TurboSlide:

1. Ability to bend (flatten) the draw notes. Although these notes are already bendable in the conventional fashion; there is an advantage to the TurboSlide feature, namely: the ability to bend them all at once, introduce tremolo, and special tunings.
2. Ability to sharpen (bend up) the blow reeds. This is technically more difficult, and has not yet been perfected. If successful, it would provide a true “whammy bar” effect.
3. Static version: concealed magnets without slide, to allow easy tuning of reeds without filing.
4. Economy version: The current TurboSlide is based on the Seydel Silver, which is one of the only harps having paramagnetic reeds. This is a very high quality harmonica, but also very expensive. We have experimented with modifying brass-reeded harps to make their reeds more magnetic, thereby providing the same functionality for nearly half the cost..
5. You tell us! What features would you like to see? We’re always listening.



The future model *TurboSlide* could also be equipped with a non-moveable magnets, to offer static altered tunings. For example.

altered tone	MELODY MAKER	C	E	A	C	E	G	C	E	G	C
	NATURAL (HARMONIC) MINOR	C	E $\flat$	G	C	E $\flat$	G	C	E $\flat$	G	C
BLOW TONES		C 262	E 330	G 392	C 523	E 659	G 784	C 1046	E 1318	G 1568	C 2092
	HOLE	1	2	3	4	5	6	7	8	9	10
DRAW TONES		D 298	G 392	B 494	D 587	F 698	A 880	B 968	D 1191	F 1397	A 1760
NATURAL MINOR		D	G	B $\flat$	D	F	A	B $\flat$	D	F	A
HARMONIC MINOR		D	G	B	D	F	A $\flat$	B	D	F	A $\flat$
MELODY MAKER		D	G	B	D	F $\sharp$	A	B	D	F $\sharp$	A

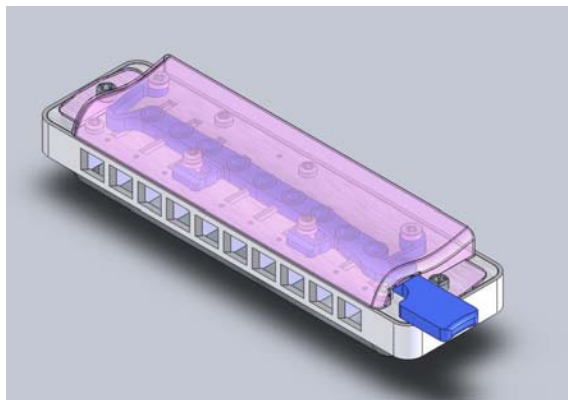

Additionally, the magnets may be used simply to allow the player to re-tune his/her harmonica, without needing to file down the reeds. Go to [www.turboharp.com](http://www.turboharp.com) for details, or email [info@turboharp.com](mailto:info@turboharp.com).



A future version of the *JurboSlide* will also allow tones to be sharpened:

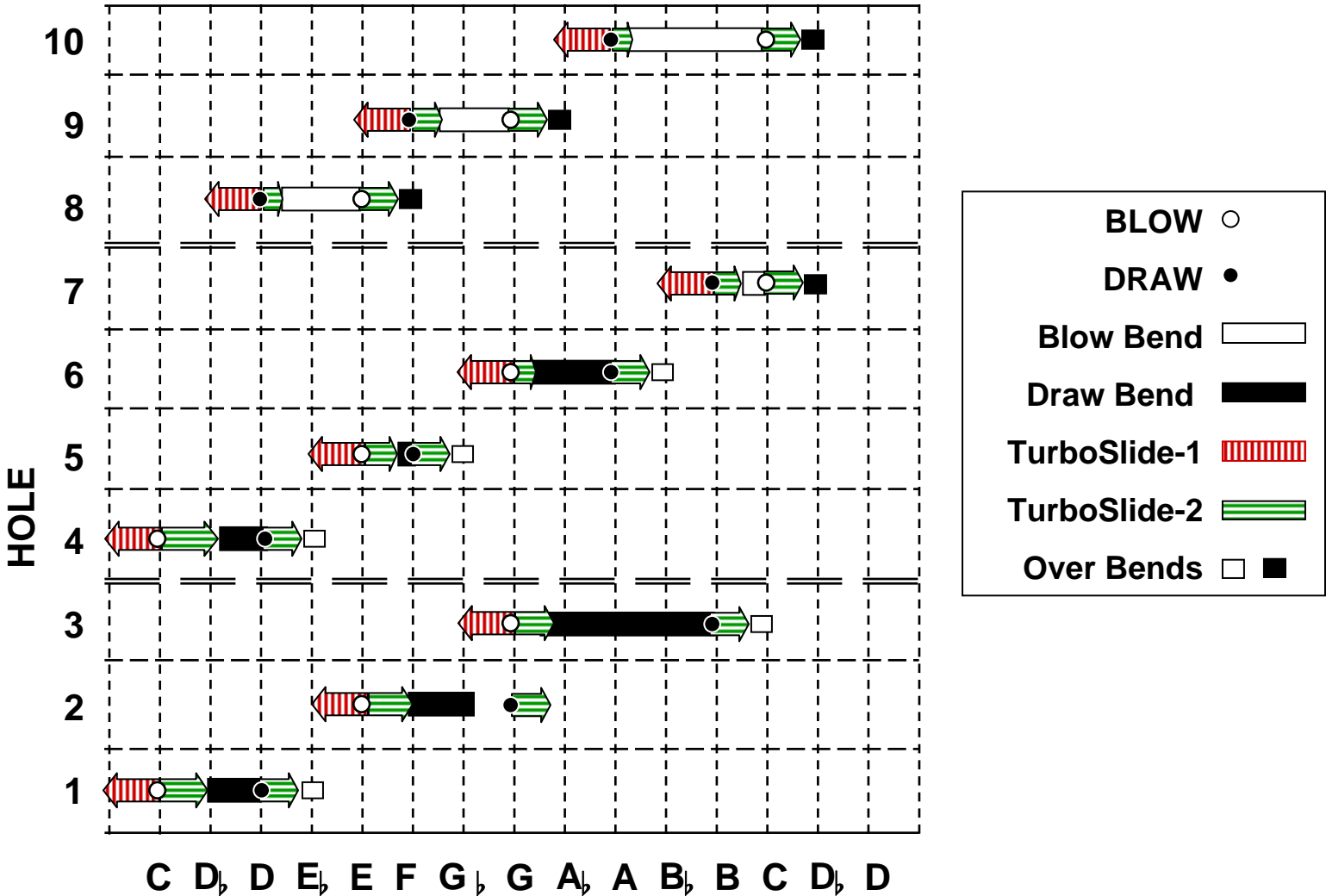

## OPERATING INSTRUCTIONS

Its really very simple... and almost self explanatory. Just press the button, in the direction shown. You may press the button before blowing to play a fixed pitch, or while you're blowing to produce a bend. Think of it as a whammy bar for the harmonica.

Here are a few additional fun things to try:

1. Press the button repeatedly while blowing to produce a tremolo effect. It almost sounds like a Hammond organ.
2. Play a chord, then bend all the notes at once... a "slow motion" effect.
3. Try bending any of the lower notes on the harp in the usual fashion, then depress the slide: notice how they go even lower! (You can also press first, bend later.)
4. If you're in to overblowing, try pressing the slide just before attempting to overblow. Notice how much easier they are to hit perfectly.

The possibilities have yet to be explored. Let us know what you discover!

## MAINTENANCE

The *JurboSlide*<sup>™</sup> should be treated with care... like any other harp. If you wish to adjust the pitch of any of the (bent) notes, you can remove the cover plates (with the provided phillips screwdriver) and turn any of the setscrews clockwise (for lower pitch) or counter clockwise (for higher pitch.) You may remove the magnet on any particular hole altogether to eliminate the bending effect

## PRECAUTIONS

- Because the The *JurboSlide*<sup>™</sup> employs high-strength permanent magnets, although small, it is advisable not to place your credit card or ATM card in near proximity: like next to your wallet. There have yet been any reports of this happening, but better safe than sorry.
- If adjusting the setscrews, do not overtighten so as to permit the magnet to poke out the bottom of the rack. This will distort the rack, and probably get caught when you press the slide.

## TUNING & TWEAKS

**Tuning:** On some models,\* the degree of bending (bend depth) of the TurboSlide can be altered somewhat by adjusting the tuning magnets. To do this, you must first remove the cover plates. A small Phillips screwdriver has been supplied for this purpose. Once removed, the magnet rack is exposed in which there are ten small screws containing the magnets. Loosening the screws will diminish the flattening effect; while tightening will accentuate the effect. **But be advised that the screws do not have a lower “stop.” Therefore you should be careful not to over tighten. If you see the rack bending as you tighten, or see the magnet protruding out the bottom, you’ve gone too far. This will not damage the harp, but will throw off the tuning of all the other reeds.**

**Replacing Magnets:** Your harp should have come with at least one “spare” magnet.\* In the event that something happens to one of the magnets, for example if the threads or screw slot becomes stripped. Replacing the magnet should normally be a simple matter of unscrewing the old one out, and the other back in its place. The TurboSlide is usually shipped with high-power magnets. Although they can be adjusted,\* you might find they are just a little bit “too” strong. We also supply optional “medium” and “low” power magnets which can be easily swapped in. You can purchase replacement magnets on our website, or by contacting us directly.

**Stiffness.** The slide lever is intentionally designed to be stiff, so as to provide force-feedback the player. But you might prefer a softer response. There are two ways to do this. One is to remove the screw marked “A” on the diagram below. This will eliminate the right most leaf spring from the mechanism. The screw can be left out without affecting the function of the harp. If you wish to make this permanent, you can simply “prune” the leaf spring with wire cutters, a sharp razor blade, or nail clippers.

**Stiction.** If you find that the slide mechanism become “sticky,” it might be caused by over tightened retaining screws. Try loosening screws **D**, **B**, and **A** one a time to see if this solves the problem. Only a tiny twist will have a big effect. (Note, screw **C** is not currently used.)

**Reed Gapping.** Due to the attractive force of the TurboSlide magnets, they tend to reduce the gap of the reed when the slide is depressed. Sometimes this can cause the reed to “choke.” If you find this to be the case, you might try enlarging the gap slightly. Instructions how to do this are available on several websites, including ours.

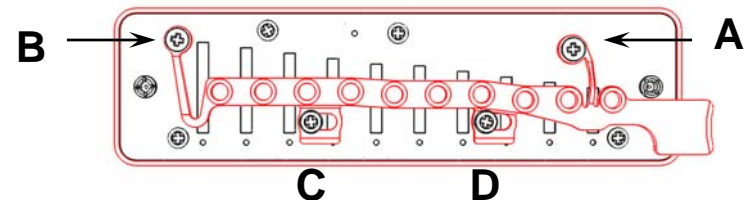

\* The higher pitched harps, key of D and above are equipped with bonded magnets that are not adjustable

*If you run into any kind of trouble, don't hesitate to contact us. We are committed to making your TurboSlide experience a satisfying one. If we cannot solve your problem remotely, we are pleased to service your harp in our shop.*

## TurboSlide Survey

*We value your opinion. If you enjoy playing the TurboSlide, please tell your friends. If you are not having fun with it, or encountering problems, please tell us!. We value your opinion. In fact, we depend on it!*

*Whenever convenient, we would greatly appreciate you taking some time to complete this survey.*

1. Do you think this instrument offers any advantages over the Diatonic or Chromatic harmonica? \_\_\_\_\_
2. If you have ever played an XB40, we'd like to ask the same question. \_\_\_\_\_
3. How about a Valved Suzuki Promaster? \_\_\_\_\_
4. Did you feel inhibited by being unable to bend the blow notes? (Y/N) \_\_\_\_\_
5. If we were to add the ability to bend any notes up, would you find that useful? (Y/N) Which ones? \_\_\_\_\_
6. How far would you like to be able to bend with the slide? ½-step? whole step? more?
7. Check this out: try bending hole 3 or 4 in the normal fashion; then press the slide. Do you notice that you are able to bend further? (Y/N) If so, is this a good thing? (Y/N) \_\_\_\_\_
8. The spring in the slide was intentionally made stiff to provide force-feedback, and prevent sudden "switching" effect, but rather a smoother bend. Did you find it to be TOO stiff? (Y/N) \_\_\_\_\_
9. What is your opinion of a static version in which there is no slide, but individual reeds may be tuned (magnetically) by a small setscrew?
10. We are contemplating several tunings for the slide version. Please let us know your opinion:
  - a) pre-tuned, half step, not adjustable by user. \_\_\_\_\_
  - b) alterable in increments by adding/removing magnetic plugs into the magnetic rack \_\_\_\_\_
  - c) fully adjustable with setscrew to allow easy pitch adjustment. \_\_\_\_\_
11. How do you like the name *TurboSlide*? Does it convey the meaning/function of the harp? (Y/N)
  - a) Do you prefer *TurboSlide*? (Y/N)
  - b) Could you recommend an even better name? \_\_\_\_\_
12. Feel free to make any additional comments that you think might be helpful improving the TurboSlide (continue on back or page, or use additional sheets as necessary).

YOUR NAME, PLEASE: \_\_\_\_\_

Please email this page to:  
[antakamatics@turboharp.com](mailto:antakamatics@turboharp.com)

*Thanks again, Tell your Friends!!!*

